

**Operating Manual
Mellow Tone Amps
Universal Phono Preamp
v1.0**

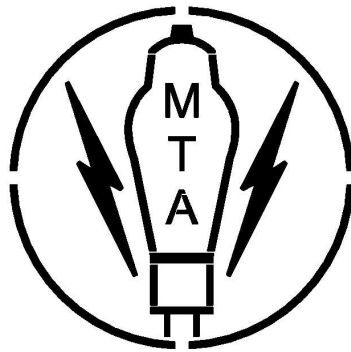

- **Letter of Introduction**
- **Warnings**
- **Features & Specifications**
- **Operating Guide**
- **RIAA Comparison Chart**
- **Full Frequency Sweep**
- **Power Supply Schematic**
- **Preamp Schematic**
- **Parts List**
- **Hardware & Wire List**
- **Troubleshooting**
- **Addendum (Important! Download Current Version)**

Date_____

Purchaser_____

Product **Universal Phono Preamp**

Serial No **1.0** – _____

Thank You for choosing the **Universal Phono Preamp!** Please take the time to go over the Operating Manual and if building the Kit version, watch the build videos - YouTube - Mellow Tone Amps.

Should you have a question, problem or just need a kick in the pants, feel free to send us an email mellowtoneamps@protonmail.com

Our Prime Objective is to build a SIMPLE, but GREAT sounding Pure Class A (zero feedback) Quasi Dual Mono Phono Preamp.

But never forget the SECOND Objective – which is to have FUN!

If at some point you're getting tired and making mistakes or NOT having Fun, put down the soldering iron (turn it off) and walk away from the work bench. I guarantee you'll come back to it FRESHER and ready to do your best work!

Cheers,

James (Jim) Lambton, President
Mellow Tone Amps Ltd.

!!!WARNING!!!
Please actually read this!

Tube amplifiers can have very high heat and voltages present. Which are fire, burn, and shock hazards. Use extreme CAUTION when working around them. Read and carefully follow the recommendations in this build manual.

If you are unsure of how to operate this amplifier safely, please contact the manufacturer at mellowtoneamps@protonmail.com

Caution!!! Capacitors can hold a LETHAL charge, always discharge them before working on any Electronic Equipment

Never use the amplifier with a damaged power cord.

Do not operate the amplifier in moist or wet conditions.

Do not operate the amplifier if chassis is open or damaged.

Always turn the volume to zero before powering on the amplifier.

Do not place flammable items on or around the amplifier.

Do not operate the amplifier in an enclosed space.

Do not operate the amplifier without adult supervision if small children or pets are present.

Never leave the amplifier on and unattended.

Never use tubes that are damaged, untested, unknown, or not listed as compatible in the manual.

**If significant smell, sparks, heat, or flames are present.
Unplug immediately.**

Features & Specifications		V1.0	Mar 03/25
<ul style="list-style-type: none"> • Universal Power Transformer (110Vac – 240Vac) • Pure Class A With Passive RIAA EQ (No Feedback) • Choke Filtered Quasi Dual Mono Power Supply • Fuse Protection On Transformer Primary & Secondary • 6.3 Vac Filament Supply For Cathode Follower • 6 or 12Vdc SMPS Input For Preamp Tubes • Single Pair of RCA Input & Output Jacks • Switchable Input Resistor & Capacitor Loading • Large Number Of Compatible V1/V2 (Preamp) Tubes • Easy To Solder Dual Sided PCB With 2oz Copper Traces • "Sandwich" Construction For High Rigidity • Ultra Short Signal Paths • Suitable For MM (Moving Magnet) and MI (Moving Iron) Cartridges • For MC (Moving Coil) Cartridges a step up Preamp or Transformer will be required 			
Compatible Tubes	V1/V2: 6SL7 / 12SL7 / 7F7* / 14F7* / 6SU7 / 5691 V3: 6N6P / 6N6P-I *With adapters or rebased		
Tubes Used In Testing	Sylvania 7F7 Rebased & NEVZ 6N6P		
Signal To Noise Ratio	60 dB @ 1Khz		
Input Impedance	47 Kohm (supplied) / Custom Jumper Selectable		
Output Impedance	1.29 Kohm		
Power Consumption			
Amplifier		SMPS	
11 Watts		4.6 Watts	
Input Sensitivity Into 220 Kohm Load @ 1 Khz			
Input	Output		Gain
5.0 mVrms	0.973 Vrms	45.78 dBv	194.6
THD (Total Harmonic Distortion) @ 1Khz			
0.098% / -60.2 dBr			
RIAA Frequency Deviation			
Full Frequency Response	20Hz - 10 Khz	+0.84 / -1.18 dBr	
Low Frequency Response	20 Hz	-1.18 dBr	
Mid Frequency Response	1.0 Khz	0.00 dBr	
High Frequency Response	10 Khz	-0.86 dBr	

Operating Guide	V1.0	Mar 03/25
First Steps	<ol style="list-style-type: none"> 1. Break in tube sockets with dummy tube if you have one. 2. Carefully install tubes in correct sockets, V1/V2: 6SL7 / 12SL7 / 7F7* / 14F7* / 6SU7 / 5691 V3: 6N6P / 6N6P-I *With adapters or rebased 3. Plug in power cord & Appropriate DC Switchmode Power Supply. 4. Plug in RCA inputs and output. 5. Connect turntable ground to rear ground lug. 6. Turn on power switch. 7. Turn on heater switch and let the amplifier warm up for 1 minute. 8. Turn on the rest of your system. 9. Watch for sparks, smoke, fire, and great sound (only partly joking). 10. Check for noise with volume of following preamp set to zero, then check at 1/4 volume. 11. If all good, it's time to listen to your favorite vinyl record. 	
Sound Shaping	<p>Tube rolling in V1 & V2 gives you the option to significantly change the sonics of your phono preamplifier. That's because V1 & V2 are the voltage gain tubes and will have the most influence on your sound.</p> <p>And as we all know, “The Tubes Are The Amplifiers!”</p>	
Pro Tips	<ul style="list-style-type: none"> • Locating your preamplifier away from electronic noise will reduce your total noise floor. • A higher output cartridge will also result in a lower noise floor. • Don't drop your tubes, it will annoy them (They will get all bent out of shape). And if you're really unlucky, they will break. • Don't use junk, untested, or incompatible tubes. (See First Steps #9 for possible results). • Use quality RCA patch cords, not coat hangers. (Quality cables do not require a dump truck full of cash, just don't buy the cheapest). 	
Cleaning	<ol style="list-style-type: none"> 1. Switch off and unplug power cord and SMPS. 2. Carefully remove tubes. (Place them somewhere safe). 3. Use only 99% Isopropyl alcohol and a clean micro fibre cloth. 4. Apply alcohol sparingly to micro fibre cloth and wipe down any surfaces that need to be cleaned, while avoiding the edges of the top and bottom plates. And avoid cleaning the labels on the back and bottom. 	
Replacing Primary Fuse	<ol style="list-style-type: none"> 1. Switch off and unplug power cord. 2. Use mini slot screw driver, remove fuse holder from IEC power inlet. 3. Spare fuse may be in the holder, if not refer to rear label for correct fuse. 4. Replace and re-install fuse holder in IEC power inlet. 	

Modern Line Phono Preamp v1.0 RIAA Comparison Chart

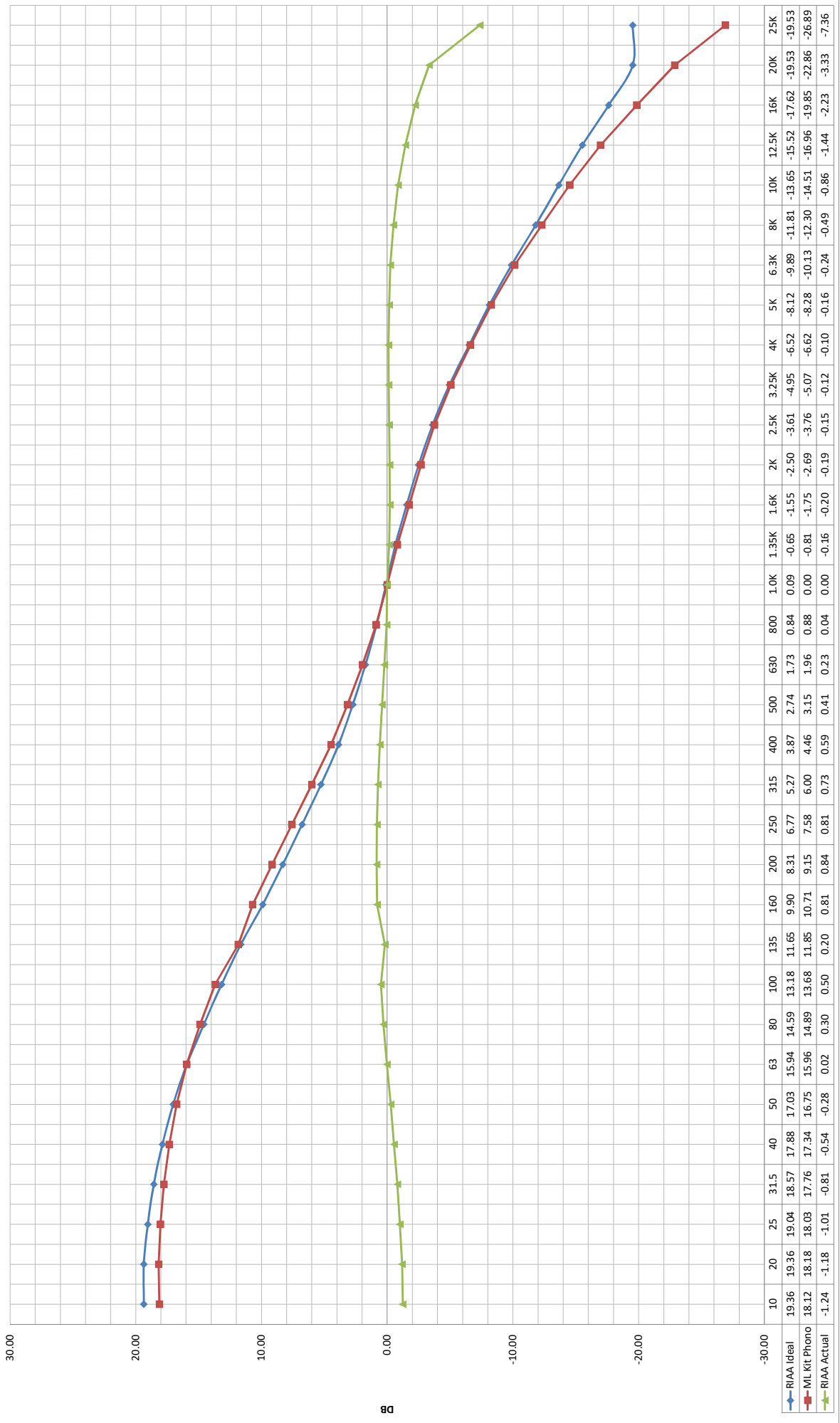

Modern Line Phono Preamp v1.0 Full Frequency Sweep

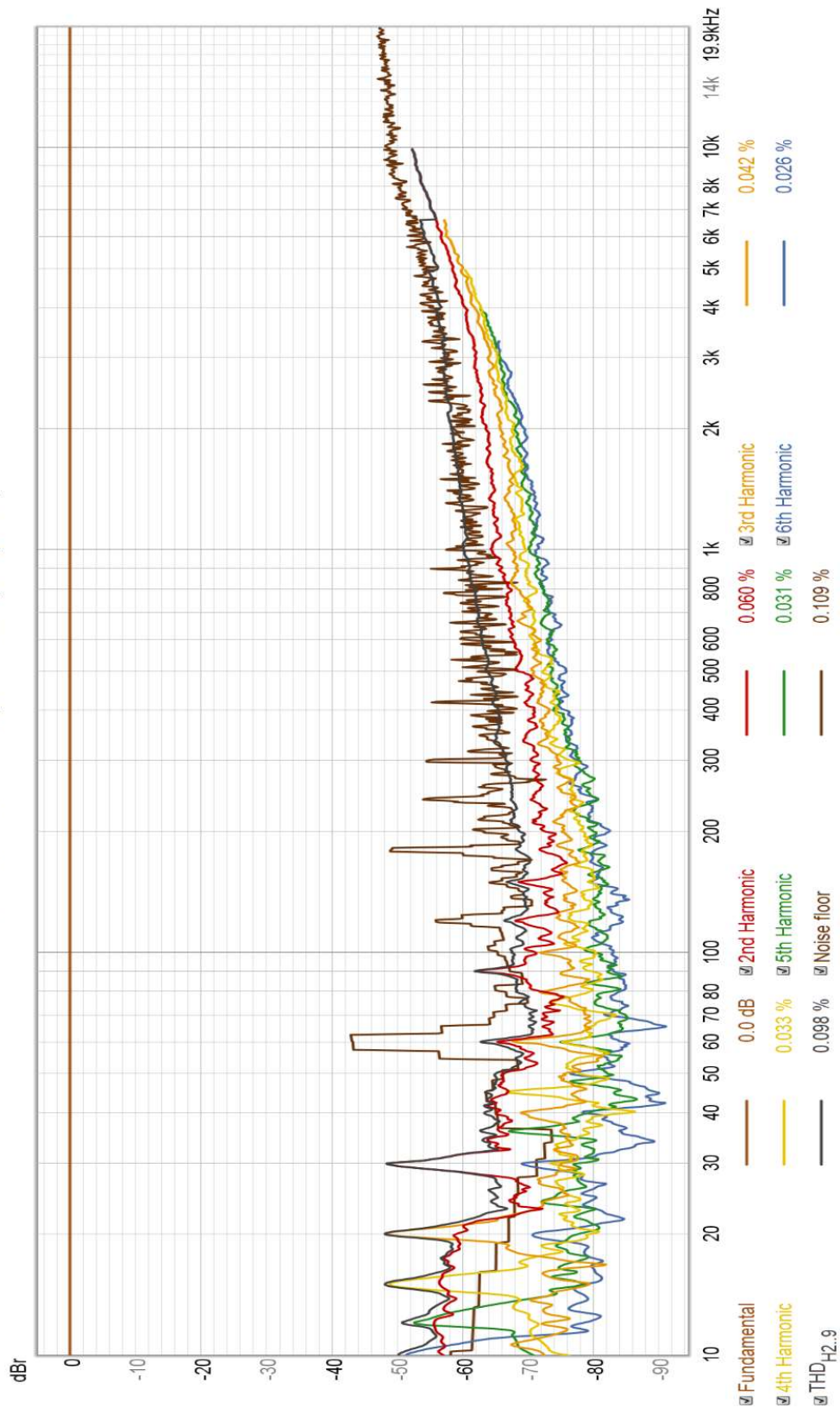

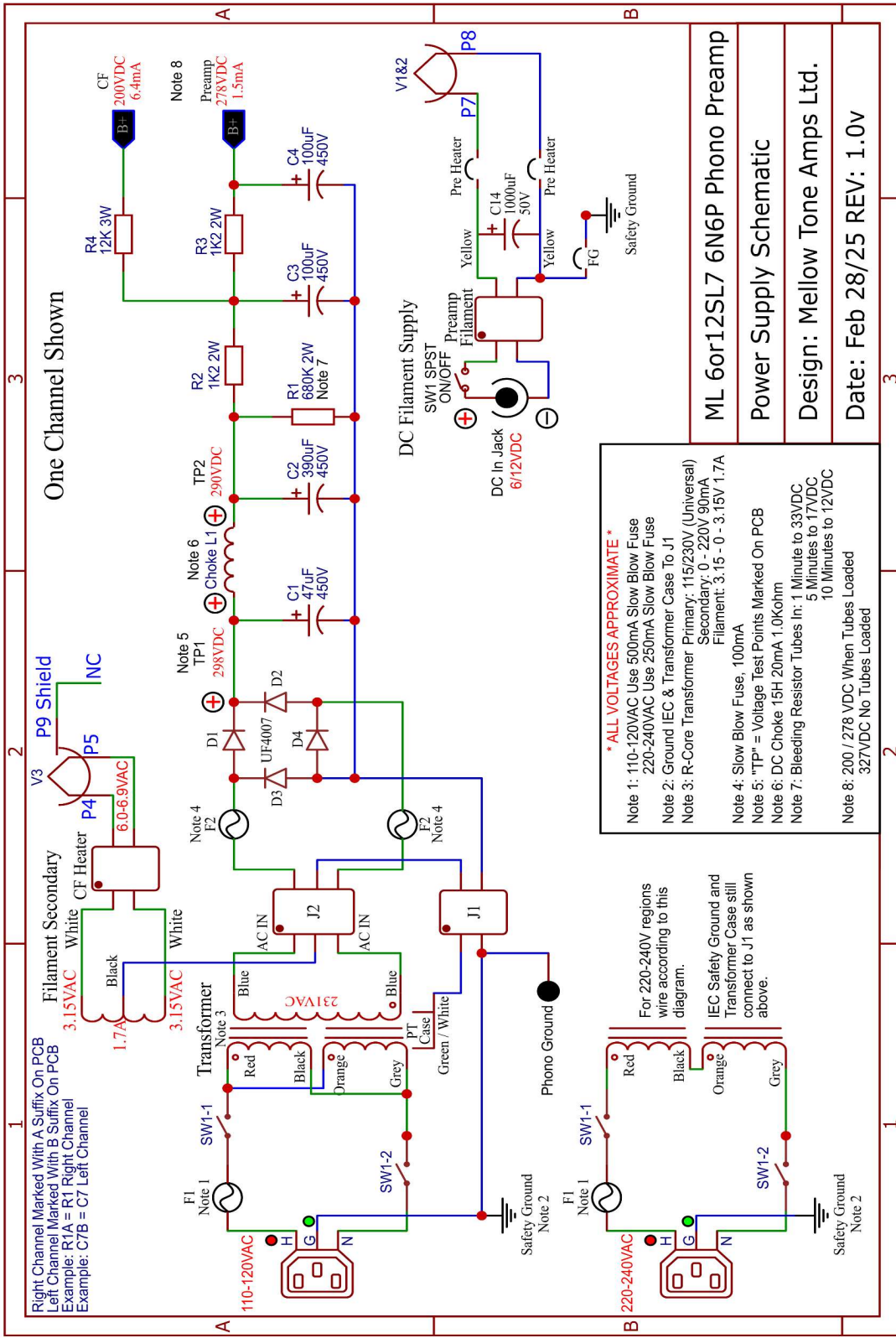

*** ALL VOLTAGES APPROXIMATE ***

Note 1: 110-120VAC Use 500mA Slow Blow Fuse
 220-240VAC Use 250mA Slow Blow Fuse

Note 2: Ground IEC & Transformer Case To J1

Note 3: R-Core Transformer Primary: 115/230V (Universal)
 Secondary: 0 - 220V 90mA
 Filament: 3.15 - 0 - 3.15V 1.7A

Note 4: Slow Blow Fuse, 100mA

Note 5: "TP" = Voltage Test Points Marked On PCB

Note 6: DC Choke 15H 20mA 1.0Kohm

Note 7: Bleeding Resistor Tubes In: 1 Minute to 33VDC
 5 Minutes to 17VDC
 10 Minutes to 12VDC

Note 8: 200 / 278 VDC When Tubes Loaded
 327VDC No Tubes Loaded

ML 6or12SL7 6N6P Phono Preamp

Power Supply Schematic

Design: Mellow Tone Amps Ltd.

Date: Feb 28/25 REV: 1.0v

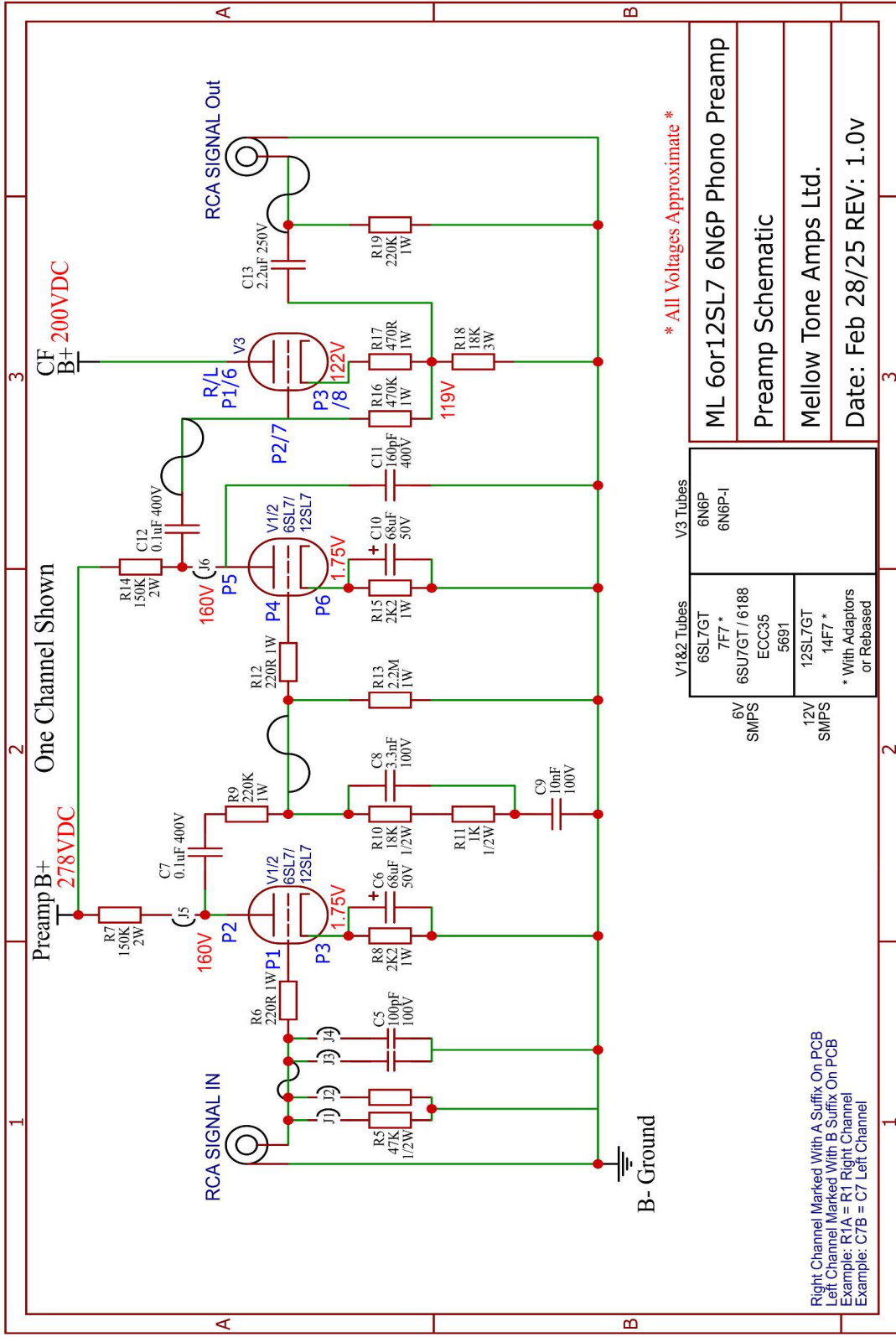

* All Voltages Approximate *

ML 6or12SL7 6N6P Phono Preamp
 Preamp Schematic
 Mellow Tone Amps Ltd.
 Date: Feb 28/25 REV: 1.0v

V1&2 Tubes		V3 Tubes	
6SL7GT	6N6P	6N6P	6N6P-I
7F7 *	6V SMPS	6SU7GT / 6188	
ECC35		12V SMPS	
5691			
12SL7GT			
14F7 *			
* With Adaptors or Rebased			

Right Channel Marked With A Suffix On PCB
 Left Channel Marked With B Suffix On PCB
 Example: R1A = R1 Right Channel
 Example: C7B = C7 Left Channel

Parts List	Universal Phono Preamp	v1.0 Mar 3/25
-------------------	-------------------------------	----------------------

Qty	Power Supply	Description	Product Number	Plan #
1	Universal R-Core PT	pri: 115v/230v sec: 0-220v 90mA	special order	
1	Transformer Cover	black (2 sides + lid)		
1	IEC inlet (safe type)	c/w fuse & switch	AC-01A KCD5	
1	PCB	ML 6or12SL7 Phono Preamp	v1.0 Oct/24	
2	Fuse (1 spare incl)	Slow Blow x 20mm (120Vac/230Vac)	500mA/250mA	F1
2	Fuse	Slow Blow x 20mm	100mA	F2
9	Diode	1A 1000V	UF4007	D1-D4
2	Choke	Triad 15H 20mA	C1-X	L1
2	Capacitor	radial	47uF 450v	C1
2	Capacitor	snap in (d30 x h45mm)	390uF 450v	C2
4	Capacitor	radial	100uf 450v	C3, 4
2	Resistor	metal film 1%	680k 2w	R1
4	Resistor	metal film 1%	1k2 2w	R2, 3
2	Resistor	metal film 1%	12k 3w	R4
Preamp				
2	socket	ceramic - pcb type	8 pin octal	
1	socket	ceramic - pcb type	9 pin miniature	
4	RCA female jacks	high quality isolated ground		
1	Switch	SPST (on-off)		
1	DC female jack	metal housing (grounded)		
1	Capacitor	electrolytic - radial	1000uF 50v	C14
4	Capacitor	CBB (input loading)	100pf 100v	C5
4	Capacitor	electrolytic - axial	68uF 50v	C6, 10
4	Capacitor	MPET, Vishay MKT 1813	0.1uF 400v	C7, 12
2	Capacitor	CBB (RIAA EQ)	3.3nF	C8
2	Capacitor	CBB (RIAA EQ)	10.0nF	C9
2	Capacitor	silver mica (EQ HF trimmer)	160pF	C11
2	Capacitor	MPET, Vishay MKT 1813	2.2uF 250v	C13
2	Resistor	metal film 1%	47k 1/2w	R5
4	Resistor	metal film 1%	220r 1w	R6, 12
4	Resistor	metal film 1%	150k 2w	R7, 14
4	Resistor	metal film 1%	2k2 1w	R8, 15
4	Resistor	metal film 1%	220k 1w	R9, 19
2	Resistor	metal film 1%	18k 1/2w	R10
2	Resistor	metal film 1%	1k0 1/2w	R11
2	Resistor	metal film 1%	2m2 1w	R13
2	Resistor	metal film 1%	470k 1w	R16
2	Resistor	metal film 1%	470r 1w	R17
2	Resistor	metal film 1%	18k 3w	R18
6	PCB Chassis	Top/Bottom/Side/Back Plates		
4	Corner Blocks	3D Printed ASA Black		
4	RCA Spacers	3D Printed ASA Black		
4	Feet	3D Printed ASA Black		
2	Tool-RCA Jack Holder	3D Printed ASA Black	RCA1	
1	Wire/Connectors/Heatshrink/Hardware Pack			

Qty	Description	Product Number	Notes
	4 O-ring nitrile 5x14x24mm		
4+1	brass standoff - male/female	12mm	
8	brass standoff - female/female	53mm (custom sized)	
2	pcb fuse holders		including covers
3	blue pcb junction 2p		
1	blue pcb junction 3p		
8+2	jumper 2 pin block 5mm		one strip (20 pins)
4+1	jumper 2 pin shunt 5mm		install bar UP
2	aligator clips - medium (35mm)		check for red & black
2+2	female spade - med (3/16")		no clear plastic sleeves
4+2	ring terminals - small (3mm)		
1+1	fork terminal - small (3mm)		turntable ground @ choke
2	machine screw m3 x 8mm flat hd	black	IEC
4	machine screw m3 x 12mm flat hd	black	cover lid
2	machine screw m3 x 6mm flat hd	flat head type	fuse holder
24+2	machine screw m3 x 8mm truss hd		
5+1	machine screw m3 x 12mm truss hd		
24+2	machine screw m3 x 16mm HEX truss hd		
16+2	square nut m3		
5+1	flange nut x m3		
2+1	nylock nut m3		
2+1	lock washer m3	inside teeth	
1	knurl brass m3 x 8		turntable ground
1	3M scrubber 2 x 2"		
	24" hookup wire – red (braided)	22awg stranded	
	6" hookup wire – black (braided)	22awg stranded	
	40" hookup wire – yellow	22awg stranded	
	6" hookup wire - green	22awg solid	
	10" hookup wire – yellow/green	18awg stranded	
	3" heat shrink - green	2.4mm	
	12" heat shrink - red	2.4mm	
	3" heat shrink - black	2.4mm	
	3" heat shrink - red	3.2mm	
	3" heat shrink - yellow	3.2mm	
	3" heat shrink - black	3.2mm	
	5" heat shrink - black	10.0mm (flat)	

Troubleshooting		!!!CAUTION HIGH VOLTAGE PRESENT!!!	V1.0	Mar 03/25
Issue:	Resolution:			
Amp Does Not Turn On	<ul style="list-style-type: none"> • Check power cord is undamaged and connected at both ends. • Check filament SMPS is plugged in at both ends and switched on. • If power light on rear of amplifier is unlit, disconnect power cord, remove the fuse from the back, test and replace. (500mA Slow Blow For 110-120 Vac, 250mA Slow Blow For 220-240 Vac) Note: Fuses wear out over time! • If issue unresolved, internal 100mA fuses may need to be replaced and the amp should be brought to a professional for servicing to identify the reason the fuses blew. 			
No Sound	<ul style="list-style-type: none"> • Check the amplifier is powered on. • Check RCA cables are connected to input RCA jacks and turntable. • Ensure RCA output is properly connected and that the rest of the system is configured and working correctly. • Ensure tubes are lamping (glow from filaments). If no glow, check if SMPS is correct voltage (6v for 6SL7 & 12v for 12SL7 tubes) and use a multimeter to check for correct DC voltage present at DC jack. • Re-seat the tubes, clean the pins if signs of oxidization are present. • Replace tubes with known good ones. • If unresolved, bring amp in for servicing. 			
Noise	<ul style="list-style-type: none"> • Make sure a good Ground Connection exists from the Turntable chassis to the ground lug on the rear of the preamp. Note, some Turntable manufacturers (Rega in particular) place the chassis Ground on the Left RCA shield, which can induce noise on that channel. It is a fairly easy job to disconnect the ground on the Rega output PCB and attach a proper Ground wire to a machine screw on the Turntable chassis (clean a wee bit of paint off the contact point of the ground wire.) • Test other components in system individually to narrow down the source of the noise. • Wireless sources such as Phones, Bluetooth, and WIFI may introduce electronic noise if placed close to the amplifier. Power off these devices or move them further away to see if the noise is reduced. • Ensure all audio cables and RCA jacks are clean and not oxidized. Clean with electrical contact cleaner if necessary. • Ensure tube pins and socket receivers are clean and making good electrical contact. • Replace tubes one at a time with known good tubes and try to identify which tube is noisy. • If unresolved, bring amp in for servicing. 			
Distorted Sound	<ul style="list-style-type: none"> • Ensure compatible tubes are being used. • Ensure phono stylus is very clean and in good working condition. 			
Smoke, Smell, Fire	<ul style="list-style-type: none"> • Unplug the amplifier and bring in for servicing. 			
Music Sounds Bad	<ul style="list-style-type: none"> • Get better music. 			

Changes to the Build, Schematic, Parts, or Important Information Supplemental to the Build Manual and YouTube Build Series are located here.

Note: Always download the latest Addendum sheet available at mellowtoneamps.ca under the download section for your amplifier.